

1. PREPARATION BEFORE INSTALLATION

Important points that must be paid attention in the installation area:

- ◆ There could be some accidents risks when installation will be done on the roof or terrace. Therefore, required precautions should be taken against the accidents.
- ◆ Determine the area installation area.
- ◆ It should be obeyed to the construction conditions, technical conditions and regional directions during installation.
- ◆ If the collector will be installed on the roof, the collector must be mounted on south side and should be directed to the south. If it is possible the collector should be installed on the south side of the chimney. While, fume that becomes from chimney can make dirty the glass of the collector.
- ◆ Trees, high buildings chimneys... etc. should not make shadow to the collector surface.
- ◆ The collector must be installed fasten against to strong windy conditions.
- ◆ The appropriate place should be chosen for installation. The chosen place must not create a bad view for the buildings.
- ◆ The authorized installers should install the collectors.



2. INSTALLATION

Starting to installation according to the below written order. Check the nut and bolt connections.

After the installation of the chase profiles, fix the branch to the ground or roof slices. The montage angle could be chosen between 25° and 45°.

The below operations should be followed during the installation of the packaged systems.

Authorized installers must do the installation.

- To deliver the collectors, tank chase profiles and all of the other safety equipments to the working area.
- To deliver the collectors and the parts to the installation area.
- To prepare on the roof the parts regarding the chase.
- To install the chase profile.
- To install the solar tank in to the chase profile.
- To isolate the holes that opened on the roof.
- To install the collectors in to the chase profile.
- To make the installation between the collectors and the solar tank and to install the safety equipments
- To make the isolation of the system.
- To do the electrical installation to the required places.
- To make the pressure test of the system.
- To prepare the water with antifreeze and to send in to the circuit and to inhale the system air.



➤ To operate the system.

❖ **Transporting the collectors, solar tanks and chase profiles and all of the other safety equipments to the working area.**

It is forbidden to carry the collectors by putting them as vertical in the truck. The collectors should be placed parallel to the ground in order to prevent the nipples from damage. Maximum 10 pieces should be put onto one wooden case. Collectors and other equipments should be fastened with ropes.

The goods should not be opened during the transportation.

The collectors should not be stood in an inclined position in the windy areas.

Dragging on the floor must not carry the collectors.

The solar tanks should not open until the installation time.

The stainless steel covered tanks must not be damaged while during the transportation.

The pipes outlet screws of the solar tanks should be protected against damage.

Chase profiles and the above-described equipments must not be opened until the installation time and the accessories should be supplied.

After opening the packages keep away the package from the children and throw away the wasted material.

❖ **Transporting the collectors and the other parts to the installation area.**

Collectors should be pulled one by one if it is being pulled to the roof.

Collector's side screws and collector's should not be damaged until installing them to the roof while pulling the collectors to the roof

Collectors could pull to roof from the outside of the building by rope or if there is any possibility to carry them from inside to roof of the building.

If a rope pulls the collectors to roof, collector's side screws should not be damaged and collectors should not corrupted. Cause of this, rope should be fixed to system very well.

If the tank is being pulled with a rope, tank's package should not be opened and it should be fixed at least from 2 points. Tanks coat should not damage during transportation.

If chase profiles are being pulled to roof by a rope, profile's package should not open.

It must be prevented to slide down the packages during the transportation.

If installation pipes are being pulled by rope to the roof, sliding should have prevented.



Workers who are pulling collectors, solar tank and chase profile to roof should have taken all precautions and they have to fix themselves to wall with minimum two **safety belts**.

NOBODY WHO CANNOT PROVIDE ITS OWN SAFETY MUST BE ON THE ROOF FOR INSTALLING COLLECTORS.

IF THE WEATHER IS RAINY, SNOWY OR WINDY THE INSTALLATION SHOULD NOT BE DONE.

Worker who will install the collector on the roof have to wear shoe that has rubber sole. This shoe's sole have to be rough.

❖ **Preparing the parts for installing the chase profile on the roof.**

Running this operation necessitates to decide the direction of the collector and the angle. For getting maximum performance, collector's absorber surface should be settled up to straight south. To check the direction south should be found by a compass instead of watching sun.

The angle of inclination of the collector should be on the same latitude with the city for all annually usages. If consumption is only for summer period, it should be fixed on the latitude that is 15°C shorter than the city's latitude. In addition to this if consumption is only for winter period, it should be fixed on the latitude that is forward 15°C from city's latitude.

It is observed that to chose the angle of the inclination between 30°C and 40°C supplies positive results in practical.

Collector's inclination angles should have controlled by a scale or with a similar tool.

Collector's bottom sole that will be installed on the ground must not be While if the collectors installed to the ground. Collectors would have a big resistance against the wind. Always, the bottom of the collectors should be installed minimum 10 cm higher from the ground. While, the wind blows from behind keeps on it's flowing from the bottom part, too.

If there is a chimney on the roof that collector would be installed, the glass of collectors must be view to the south but it must be installed to the west side of the chimney.

Trees, high buildings etc. should not make shadow to the collector surface. The suitable place should be chosen for the collectors.

If there is a chimney on the roof that installed the collector four corner brick was mounted on the roof,

Against the strong windy conditions, the connections of the collectors and the solar tank that is fixed to the roof must be fastening. Check the connections.

If 4 edges bricks is mounted on the roof,



We are suggesting you to use aluminum material for isolation. First of all, the required numbers of brick should be taken from the roof; in order to support the additional 5 cm x 10 cm part must be nailed from bottom and upper side.

After this, aluminum coated baton material is being settled for covering bottom bricks and entering downside of upper bricks. Chases are settled for suiting axis that prepared before and it is screwed by trifon. Zinc material could be used for isolation material, too.

❖ **Installing the chase profiles**

Firstly, profiles of 1K and 2K systems that pointed on figures should be connected in another area. So, the prepared profile that is on the solar tank and other profiles became collected.

Afterwards, bottom chase profiles are installed onto the isolation that is prepared before. After this, embedded profiles will be installed.

First the profile group and the solar tank and after that it is carried up for connecting top bearers.

All screws should be controlled by one by after the installation of the chase profile.

❖ **The installation of the collectors to the chase profiles**

Collectors are mounted onto the frame profile with a “ L ” parts that prepared for collectors before. Screws should be checked. We should be sure that L part are dwelled to channel that is on the collector’s case completely. The all “L ”parts must be installed.

❖ **Making the connections between the collectors and the solar tank and the installation of the safety equipments.**

Installation chart that would settle between collector and solar tank should be like shown in the diagram.

Flexi nipples that are used for Collectors should not be used for 90°. Therefore, connection should be made with an elbow.

Plastic pipes should not be used in installation. Pipe diameters should be same with collector outlet diameters. If the collector is selective or copper, pipe diameters have to be 1”. If it is aluminum, by applying the suitable reduction to pipe, the diameter of the pipe must be grown from $\frac{3}{4}$ “ to 1 “. After this, all the other pipes should be used in with these diameters.

By using the Teflon, the connections must be done in a very good way.



If aluminum collectors are used in the system, as it is seen on the picture except the inlet and outlet pipes all other outlet pipes should be closed with a blind plug.

For the aluminum collectors by making the connection to the end of the manifold pipes Be careful by fastening the nipples, blind plugs and the any other connection. Do not fasten it too much. Other wise it could be a joint on the pipes.

By installing the whole system in order to remove the air from the system, as it is seen from the picture (1°) slope must be done to the hot water outlet of the collector. This inclination could be given practically 1 cm for each 1 meter.

If circuit pressure's value is more than 7 bars, pressure regulator should be connected to inlet of circuit absolutely.

The signed point of the 8 bars safety valve must be installed according to the direction of the tank.

Closed type expansion tank that will be mounted to system should be mounted vertically to ground as shown on the diagram.

N₂ gas pressure of closed type expansion tank is 1 bar. N₂ gas pressure will not be changed while mounting the packaged systems or later.

Pipelines should be mounted according to pipeline diagrams that are drawn for all packaged systems.

Safety equipments and other equipments should be mounted according to described pictures for all packaged systems.

❖ **The isolation of the system**

Klimaflex material should be used for installation pipes as isolation material. The dimension of this material is standard according to the diameter of the pipe.

At first, pipes should be coated with klimaflex. After that isolation should be coated with decorative band that is used for air conditioners.

All equipments should be isolated except closed type expansion tank.

❖ **Pressure test of the system**

All the equipments of packaged system should be mounted on the mounting area.

At first, see the picture 1 that explains the connection of the pipelines.

Automatic air valve is settled on the bottom of the tank.



The valve numbered 5 is being opened.

The special part numbered 7 is mounted to the hose.

We should be sure that the valve numbered 3 is open.

After this, water should be sent to circuit until overflowing from top of the tank and the valve numbered 5 is closed when overflowing happens.

Automatic air discharging system is being mounted on the part of it.

The valve numbered 5 is being opened and when the manometer shows 2,9-2,8 bars pressure levels the valve numbered 5 must be closed. We should wait for 1 hour in this position.

It should be controlled that if there is a leakage on the system.

If there is a leakage on the system, water that sent to circuit should be discharged and it should be repaired.

If there isn't a leakage on the system, the circuit is ready for working.

❖ Preparing the water with antifreeze, sending to system and discharging of system air.

We should choose mornings and evenings for sending water to system line and we should be sure that collector's surface is closed completely. It we should be sure that collectors are cold.

The water that circuiting in the closed system should be with antifreeze for precaution against freezing. Liquid that transmits the heat should be mixture with water and antifreeze rated 50 % - 50 %. It is figured below how much water and antifreeze required for preparing the heating liquid.

	THE WATER VOLUME OF CLOSED TYPE CIRCUIT (Lt)	THE LEVEL OF ANTIFREEZE IN THE MIXTURE OF HEATING LIQUID (Lt)	THE LEVEL OF WATER IN THE MIXTURE OF HEATING LIQUID (Lt)
1 K PACKAGED SYSTEM	12	6	6
2 K PACKAGED SYSTEM	24	12	12

It is prepared in the same case two different liquids.

Automatic air discharging system is being mounted if we are sure that the valve numbered 5 is closed. And the closed type circuit is being fulfilled with water-antifreeze mixture until overflow.

After this, automatic air valve is mounted to the correct place. We should be sure that the valve numbered 7 is opened.



The valve numbered 5 is opened slowly until the pressure reaches to 1-1,2 bars while the system pressure is followed through the manometer.

Meanwhile, if the system includes air, automatic air discharging system empties it.

The valve numbered 5 is being closed after the system's pressure becomes required values. The valve numbered 7 is being closed and the manometer must be demontaged. If the valve numbered 7 is not used manometer could not be demontaged.

❖ **The first start up of the system**

After the system's imperviousness control and all the components', which are in the system, coupling and location control have been completed, the system is ready to run if antifreeze water is filled up and its air is taken out in the system.

Meanwhile enclosed circuit's water is heating up and cooling down the oxygen would be released after the system's air is taken out and its first run. Released oxygen would be automatically evacuated by discharging air apparatus, so the system would lose its water level. Yet this unpreventable situation would be for a short time, and released oxygen, which is in heated liquid, will be disappeared and the system will have its ideal liquid end of this time. Therefore, the system has to be checked again and if there is lost of liquid, the system is filled up with liquid again in order to complete lack amount of liquid after a short time.

Open number 5 valves as indicated in the figure to drain collector's water. When the system is filled up with liquid again, preparing antifreeze water, filling up the system, and evacuating air should be done according to the directions.

These manufacturers' lasting life is minimum 10 years as confirmed by Industry and Trade Minister Office. Manufacturers and sellers must guaranteed required spare parts in order to run these goods' functions appropriately according to related laws for 10 years.

These goods are produced under TS 3680.

❖ **Installing electrical installation to necessary points**

Inside of one point water heater where electrical installation is installed, and 2000 watt electrical resistant is placed including with all necessary components in our plant for packet systems.

Using 2000 watt resistant has a reason to install when domestic water can not be heated enough especially for winter season. Resistant connection cables is dangled as ready position inside of the water storage's tank. Electrical resistant' connection should be installed at appropriate place by using 10 ammeter fuse. The material, would be used for electrical installation such as fuse, cable, etc, has carry standards appropriate to T.S.E. Grounding must be done for resistant connection. Resistant thermostat's connection is

fixed at 65 C in our plant. That means if resistant' is on with V – automat by consumer, resistant would not be off by itself until domestic water's temperature reaches to 65 C.

Running electrical heated resistant whenever we want it to run, it is necessary to install electrical installation and connect to a V - automat. The places where electrical cable goes through must be perfectly isolated against water.

The connection of gas water heater on collector circuit line

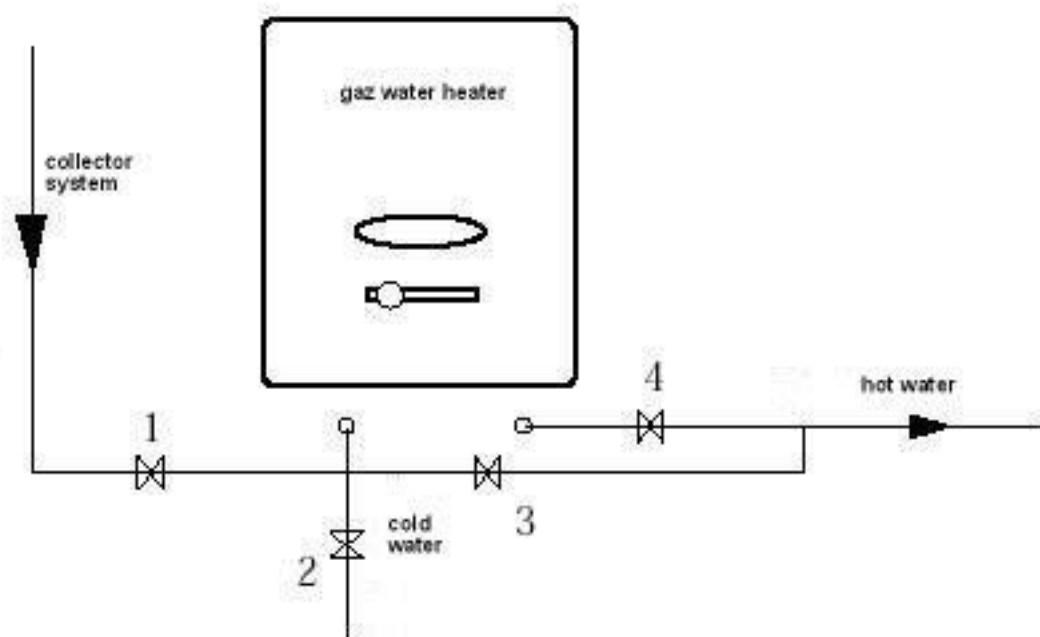

According to working conditions,
 in summer season, the valves numbered 2 and 3 must be closed
 in winter seson, the valves numbered 3 and 4 must be closed

❖ Practical Information for end users.

If the collector is hotter than it must be (when it hurts your hand) it must be understood that the liquid circulation is stopped.

Control through the manometer the valve that is connected to the circuit system send 1 bar water. Hence, the system air will be removed by the air valve and starts again to work.

If anywhere on the system is leakage control the water. If the water is colored and mixed with oil, it must be understood that the leakage is on the closed system.

If the collector glass is covered by water, there could be a joint on the collector glass.
 If your collector doe no that as it is required control the glass. Sun lights does not absorb through the dirty collector glass.



On the packaged system, the long pipe that is connected between the collector and tank is the collector return pipe. The short one is the outline pipe of the collector. If the short pipe is cold and the long pipe is hot it means that natural circulation does not work in this system. To solve this problem, please apply the method is explained on the page 9 paragraph 2.

3.MAINTENANCE RULES

1-) Discharging and Filling Up of Collector Water:

Demontage collector water's returning connection at collector's bottom side in order to drainage water in enclosed circuit system. Provide discharging of liquid. Mixing the indicated amount of antifreeze to water should not be forgotten meanwhile you are filling up the system again. If it is necessary to fill up the system again, uninstall discharging air apparatus that is top of the tank and fill up liquid until over flow. Meanwhile we are doing this process, we should prefer the time when sunlight does not effect too much and make sure collector is cold. Otherwise, hot liquid might cause injury in the system. After that, adjust closed system pressure to 1 Bar according to circumstances as indicated before.

Security valve is used in order to prevent damage by over circuit pressure in the system. Product should be cleaned at least once a year to prevent calcify.

2-) Cleaning of Collector:

Be careful for collector glass' to stay clean. Dirty and dusty glass would cause to reflect of sunlight. This prevents systems' efficiency.

3-) Winter Maintenance and Controls:

The level of antifreeze in systems' liquid should be checked on autumn months, and add on enough antifreeze to protect the goods against freezing on winter months. Guarantee does not cover product against freezing. Hot water faucet should be left little bit open for extremely cold days especially when there is a risk for freezing. Hence, installation pipes would be protected against freezing.

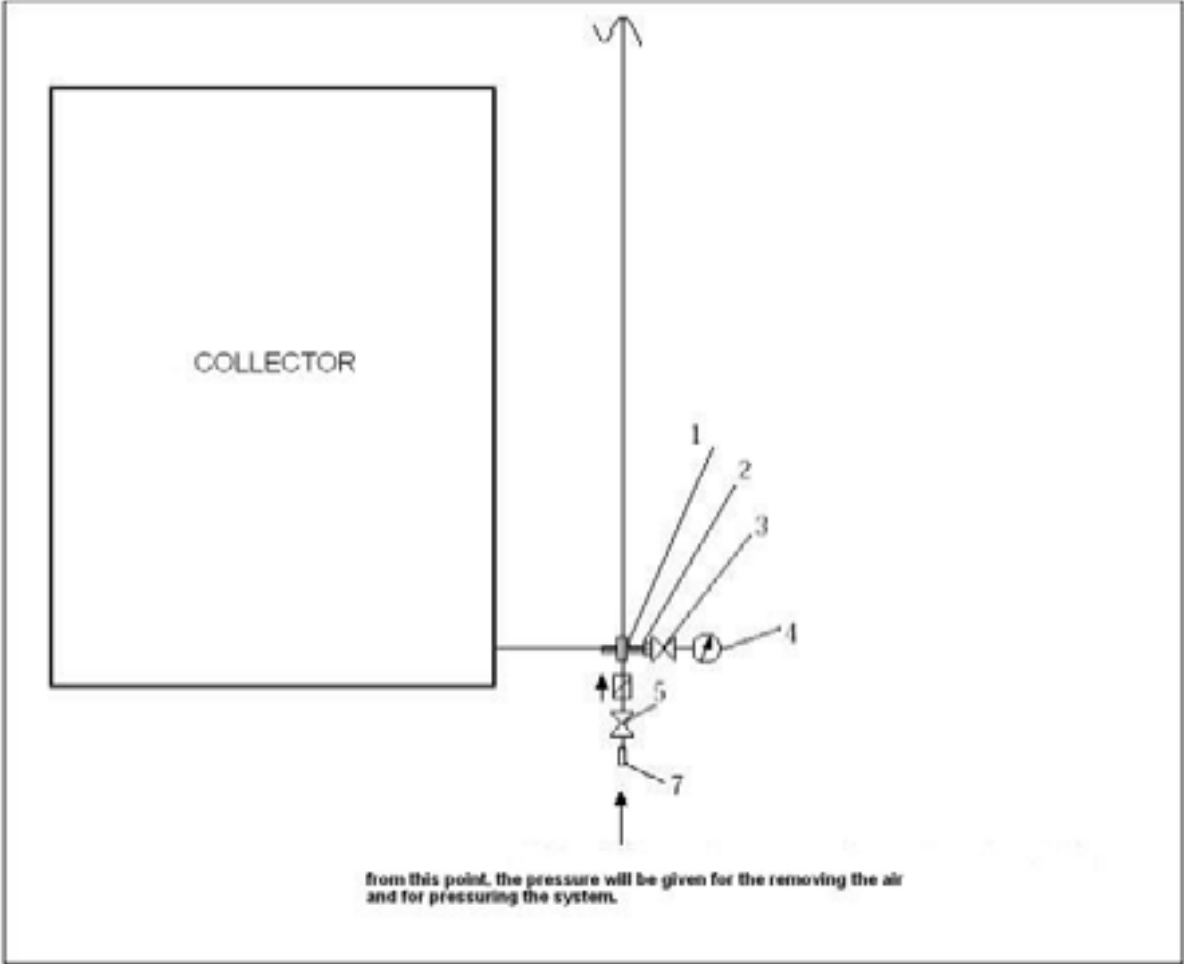

PICTURE 1

The installation table for air valve of 75-100 L.L. stainless steel covered tank

Note: Expansion tank safety valve, automatic air valve, connection equipment and tank inlet and outlet pipes will be installed during the installation. After the installation of the inlet and outlet pipes, red and blue parts will be installed. Air valve will be installed after fulfilling the anti-freeze.

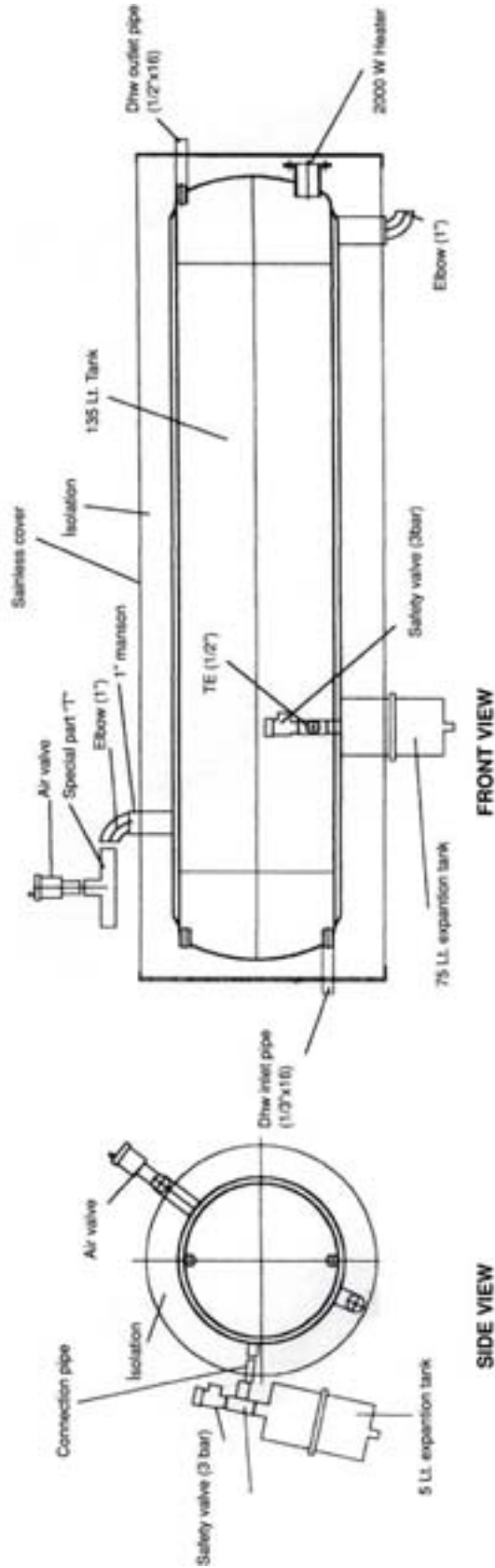

Safety equipment replacement for 2 K stainless packages system

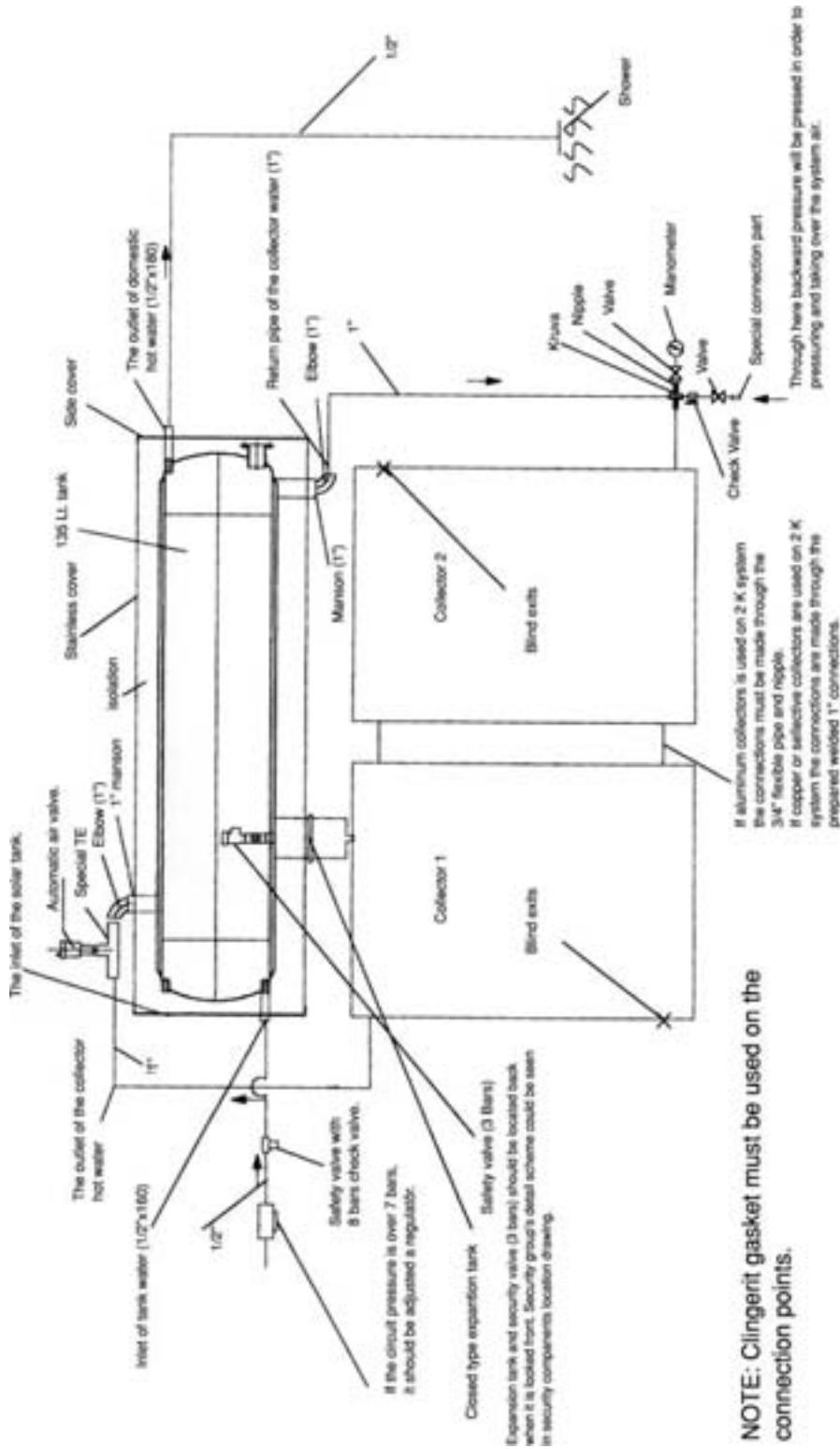

REQUIRED PIPE EQUIPMENTS FOR 2 K STAINLES PACKAGES SYSTEM

The installation table for air valve of 75-100 L.L. stainless steel covered tank

Note: Expansion tank safety valve, automatic air valve, connection equipment and tank inlet and outlet pipes will be installed during the installation. After the installation of the inlet and outlet pipes, red and blue parts will be installed. Air valve will be installed after fulfilling the antifreeze.

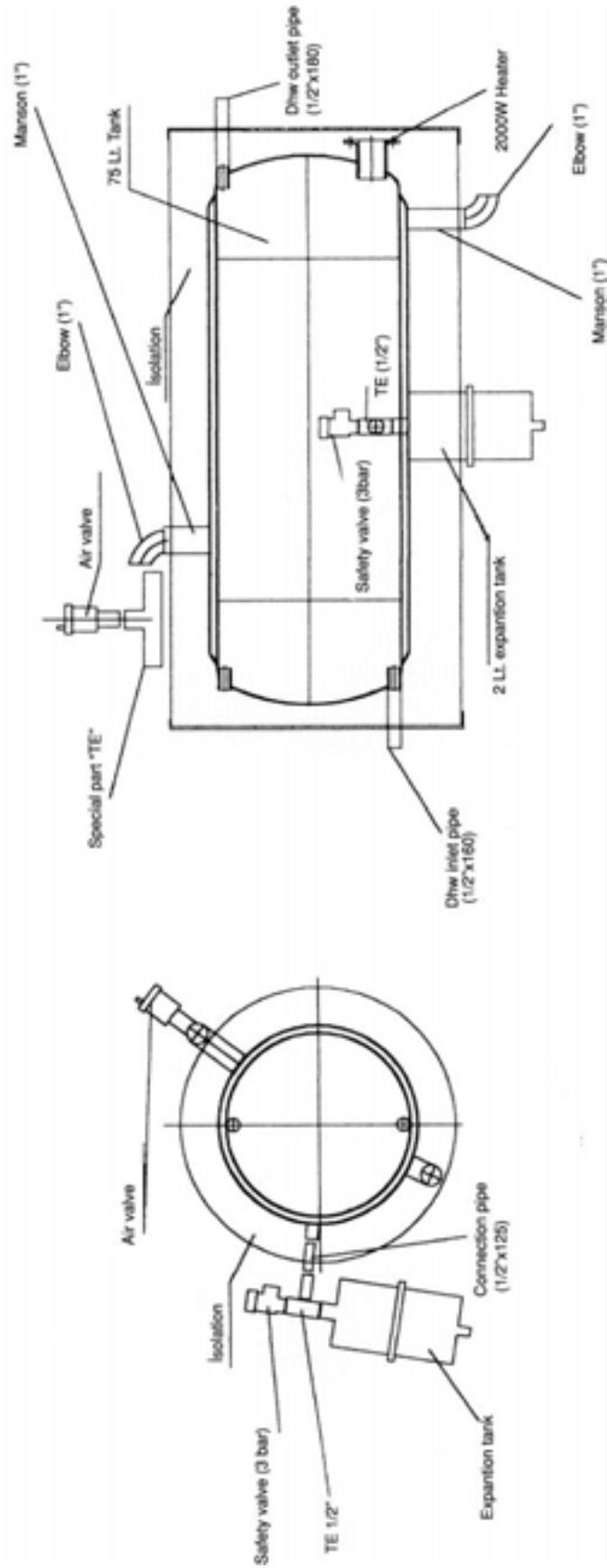

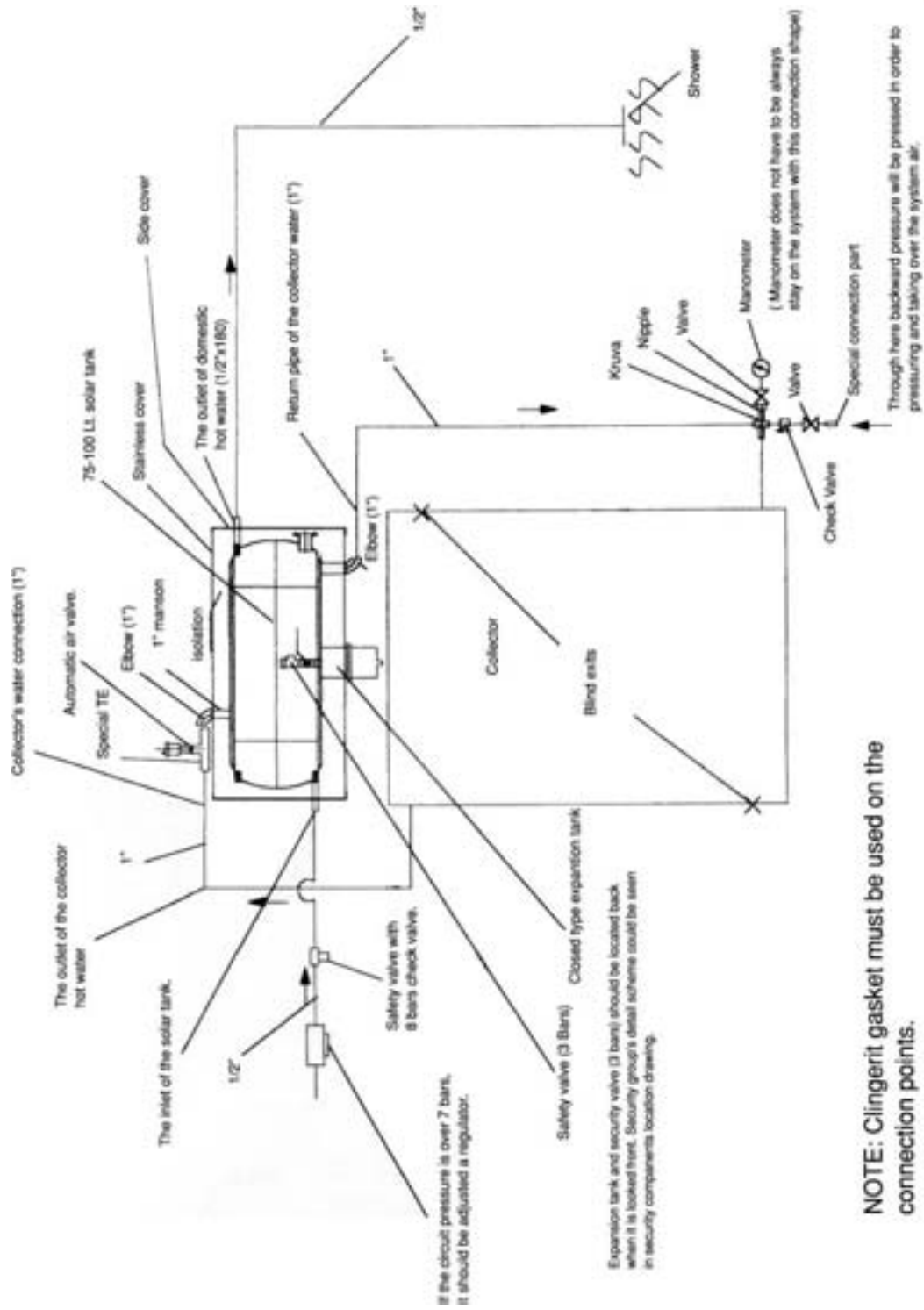

REQUIRED PIPE EQUIPMENTS FOR 1 K STAINLES PACKAGES SYSTEM

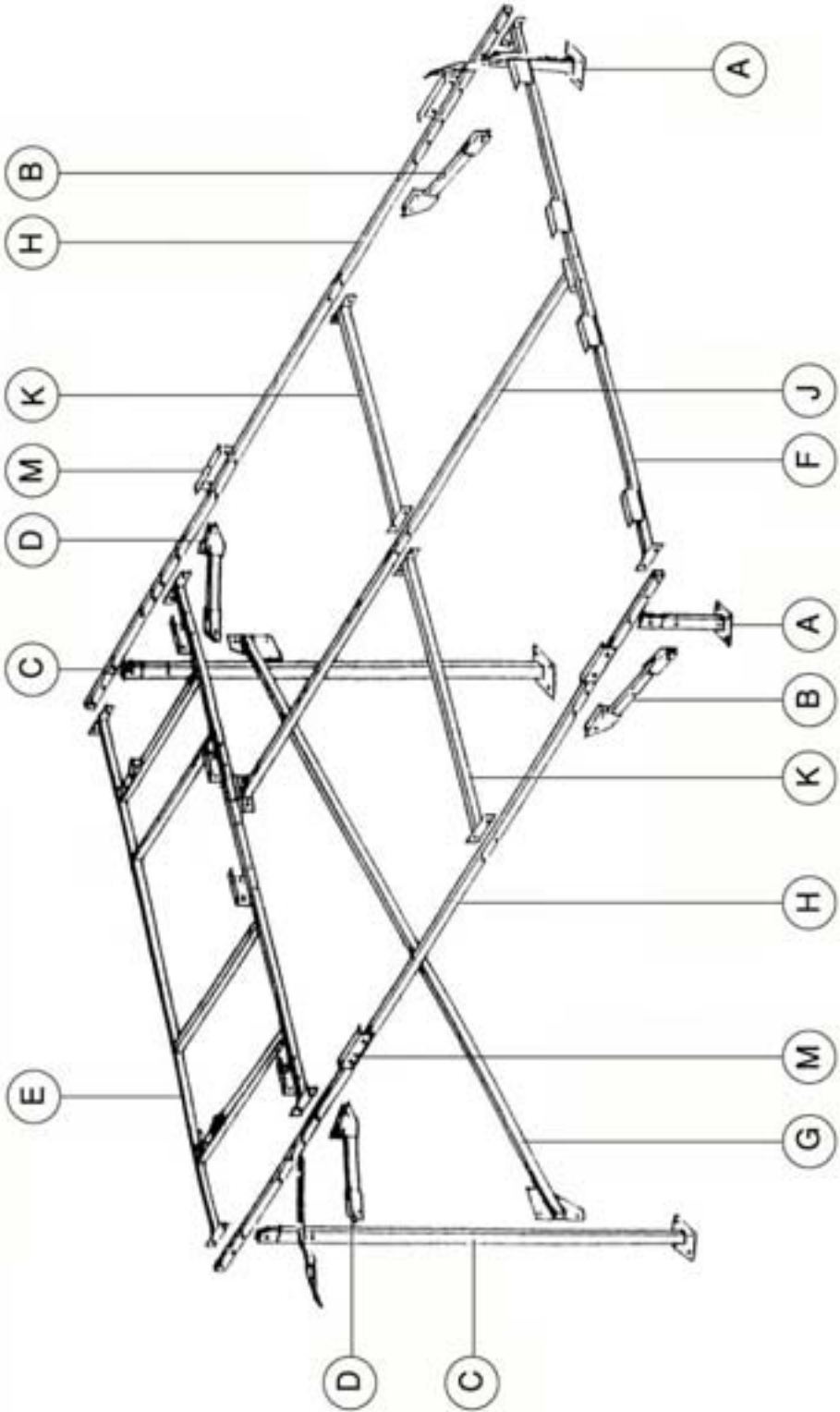

THE MONTAGE POSITION
OF 2 K PACKAGED SYSTEM

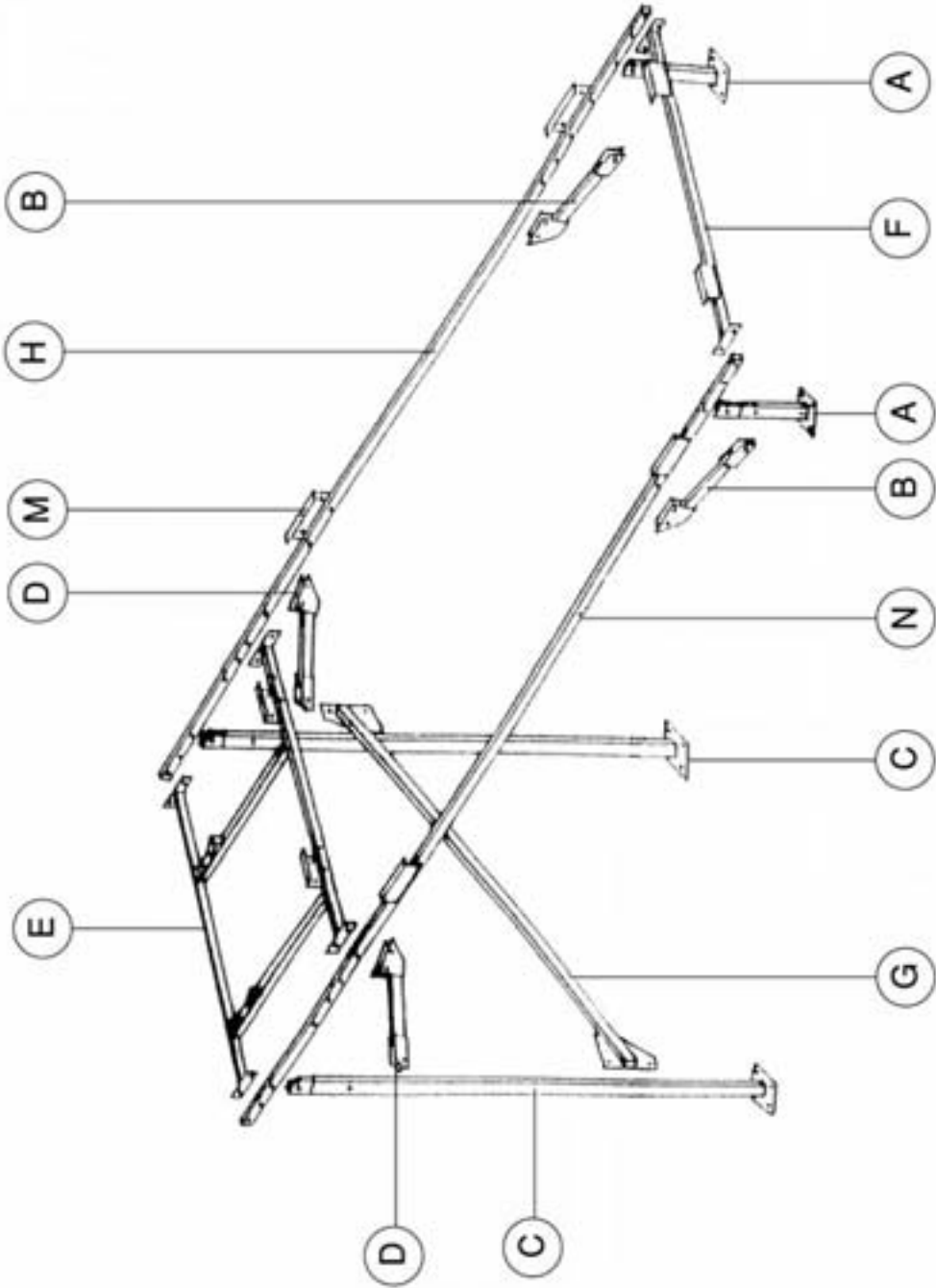

THE MONTAGE POSITION
OF 1 K PACKAGED SYSTEM

